

100W Surface Mount
CSA Approved Incandescent Hood Light With
Tempered Glass Globe

L55-2004-CSA

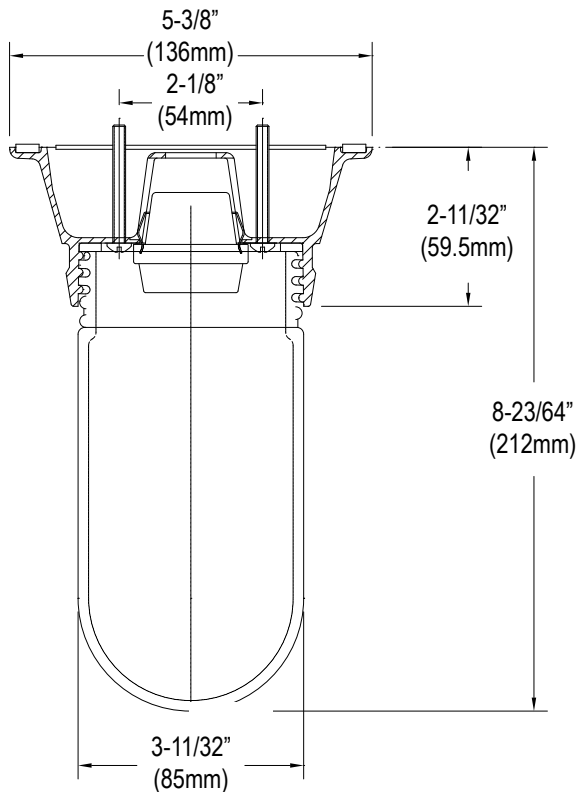

Dimensions shown in inches (mm) are for reference only and are subject to change.

Maximum Operating Temperature: 80°C (176°F)

Shipping Weight: 2 lbs

100W Surface Mount CSA Approved Incandescent Hood Light With
Tempered Glass Globe

High Efficiency, Environmentally Friendly

- Thermal and shock resistant tempered clear glass globe is ideal for commercial kitchens
- E-Z Mount Keyhole feature for quick installation
- Permanently affixed silicone gaskets speed up installation
- Designed for convenient installation into prewired hoods
- Greaseproof, waterproof & heatproof
- cULus and CSA listed for use in commercial cooking hoods
- Meets all requirements for NFPA #96 and N.E.C. 410

Features

- Fixture body is die cast aluminum with brushed finish to match stainless steel hood interiors
- Porcelain socket body with copper shell
- 16 awg, 6" (152mm) long wire leads; 18 awg green ground wire
- Accepts standard 100 watt A19 bulb (not furnished)
- Rated up to 120 VAC, 60 Hz
- Overall size - 5-3/8" (136mm) and 8-11/32" (212mm) long
- Junction box not furnished. Fixture is designed to accept any standard 3-1/2" (89mm) or 4" (102mm) junction box

Specifications

Light fixture to be Component Hardware L55-2004-CSA canopy hood light with E-Z mount keyhole feature. Lamp holder wires to be rated to 392°F (200°C). Leads to be 16 AWG with 6" (152mm) long stripped ends. Fixture to be cULus and NSF Listed.

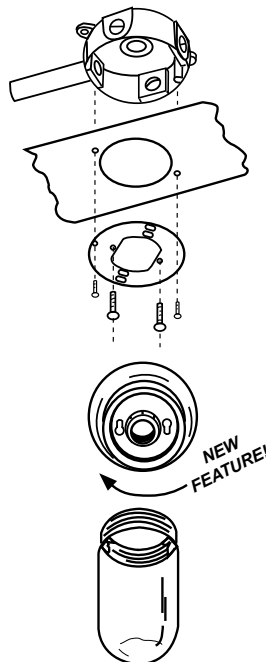

Underwriters Laboratories standard #1598 requires that light fixtures in commercial cooking hoods must be mounted a minimum of 4 ft (1219mm) above the cooking surface.

